

Ceramic salt grinding gear Monopol

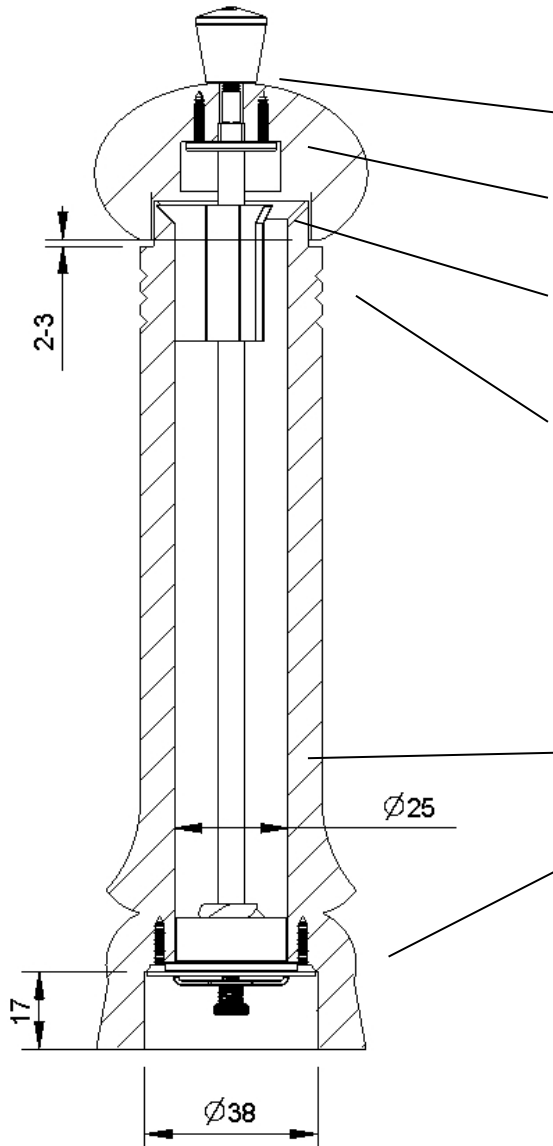

Technical instructions

Thread for knob has to be 6-8mm longer than the wooden cap

The assembled driving disk must be able to touch the end of the flat area on the axle

To assemble the centring Y a chamfer 6x45 is needed

A gap of 2-3mm between the wooden body and knob is required, to regulate the grain

The M6 thread of the axle must be glued into the ceramic cone, otherwise the ceramic part can break (2K Epoxy) The end of the axle (M6) must be glued in that the axle is 1.4 - 1.5 mm inwards. This ensures optimal regulation.

The optimal diameter of the inter chamber amounts to 25mm.

Assembling dimensions of the grinding head

Attention:

The Axle of the Sonderegger pepper grinding gear and the Monopol salt grinding gear are different. Use only the salt grinding gear axle

Parts of the Monopol salt grinding gear

Brass knob Ø16mm gold or nickel plated
 or
 Brass knob Ø12mm gold or nickel plated

Driving disc Ø20, 5mm aluminum

Plastic center Y

Axle Ø6mm stainless steel

Lengths on stock

92mm
 144mm
 185mm
 204mm

The delivery time of special lengths is about 3 weeks

Ceramic grinding head Monopol

