

Pepper grinding gear Sonderegger with plug-in part

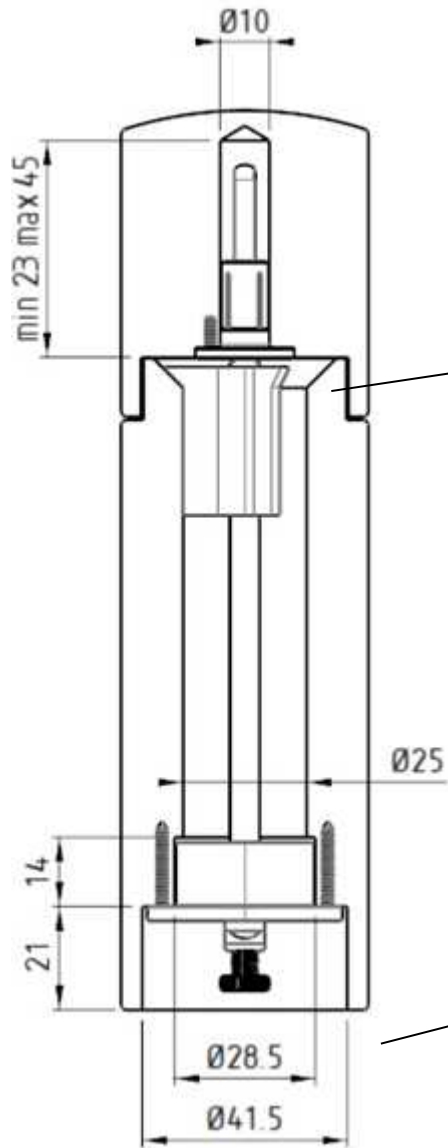

Technical instructions

To assemble the center Y a chamfer 6x45 is needed

The optimal diameter of the inter chamber amounts to 25mm. If it is smaller, then the peppercorns can block

Assembling dimensions of the grinding head

Attention:

Don't use the Sonderegger pepper grinding gear for grinding salt

Parts of the Sonderegger pepper grinding gear

Plug-in part

Driving disc Ø20, 5mm nickel plated

Plastic center Y

Axle Ø6mm stainless steel

Lengths on stock

92mm	304mm
144mm	350mm
204mm	400mm
250mm	450mm
278mm	500mm

The delivery time of special lengths is about 3 weeks

Grinding head hardened, nickel plated and pre-assembled

