

# Pepper grinding gear Sonderegger

Sonderegger Mechanik  
 St. Antonstrasse 25  
 9413 Oberegg  
 Tel. 071/891 38 72 Fax 071/891 37 25  
 E-Mail info@somec.ch  
 www.somec.ch

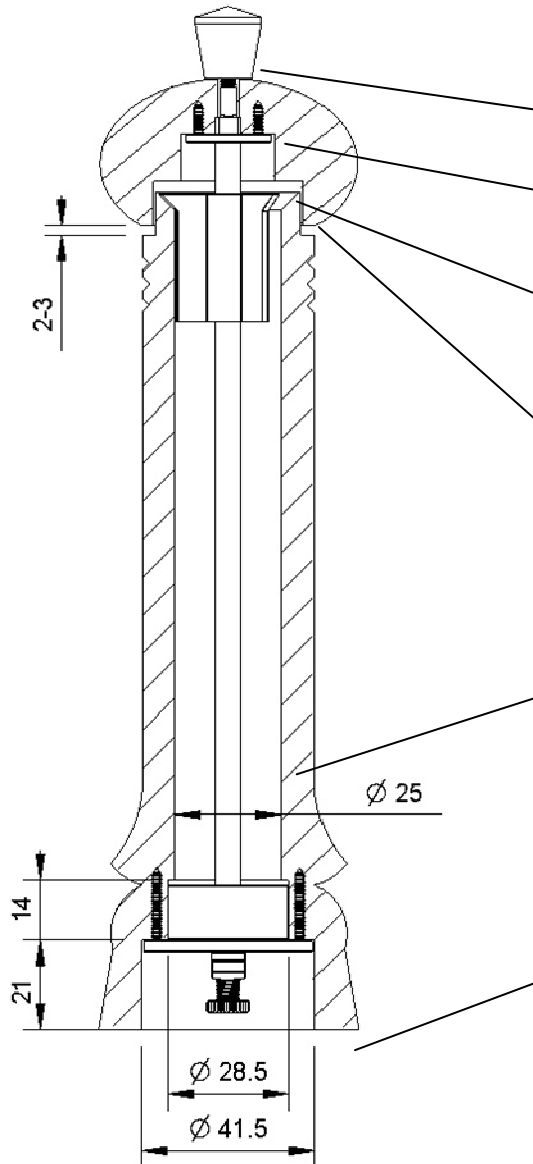

## Technical instructions

- Thread for knob has to be 6-8mm longer than the wooden cap
- The assembled driving disk must be able to touch the end of the flat area on the axis
- To assemble the center Y a chamfer 6x45 is needed
- A gap of 2-3mm between the wooden body and knob is required, to regulate the grain
- The optimal diameter of the inter chamber amounts to 25mm. If it is smaller, then the peppercorns can block
- Assembling dimensions of the grinding head
- Attention:  
Don't use the Sonderegger pepper grinding gear for grinding salt

## Parts of the Sonderegger pepper grinding gear

- Brass knob Ø16mm gold or nickel plated  
or  
Brass knob Ø12mm gold or nickel plated

Driving disc Ø20, 5mm nickel plated

Plastic center Y

Axle Ø6mm stainless steel

### Lengths on stock

92mm	304mm
144mm	350mm
204mm	400mm
250mm	450mm
278mm	500mm

The delivery time of special lengths is about 3 weeks

Grinding head hardened, nickel plated and pre-assembled

