

Ceramic salt grinding gear Monopol

Sonderegger Mechanik
 Eugst 1002
 9413 Oberegg
 Tel. 071/891 38 72 Fax 071/891 37 25
 E-Mail info@somec.ch
 www.somec.ch

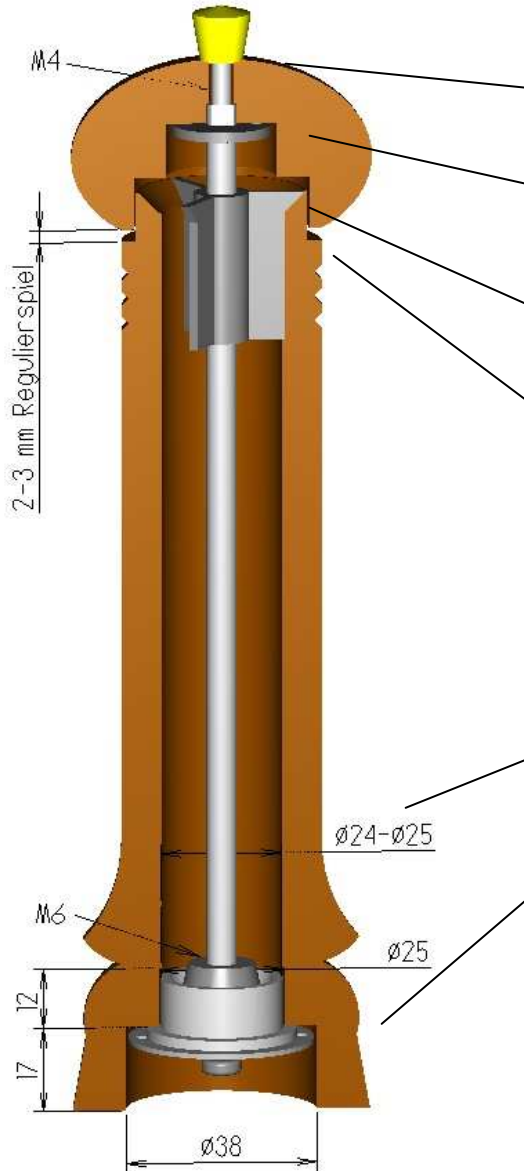

Technical instructions

- Thread for knob has to be 6-8mm longer than the wooden cap
- The assembled driving disk must be able to touch the end of the flat area on the axle
- To assemble the centring Y a chamfer 6x45 is needed
- A gap of 2-3mm between the wooden body and knob is required, to regulate the grain

The M6 thread of the axle must be glued into the ceramic cone, otherwise the ceramic part can break (use Araldit or Loctite)

The optimal diameter of the inter chamber amounts to 24mm.

Assembling dimensions of the grinding head

Attention:

The Axle of the Sonderegger pepper grinding gear and the Monopol salt grinding gear are different. Use only the salt grinding gear axle

Parts of the salt grinding gear

Messingknopf Ø16mm vergoldet und vernickelt
 Brass knob Ø16mm gold or nickel plated

Messingknopf Ø12mm vergoldet und vernickelt
 Brass knob Ø12mm gold or nickel plated

Mitnehmerscheibe Ø20, 5mm vernickelt
 Driving disc Ø20, 5mm nickel plated

Zentrierstern aus Kunststoff
 Plastic centring Y

Achse Ø6mm rostfrei
 Axle Ø6mm stainless steel

Lagerlängen
 Lengths on stock

92mm
 144mm
 185mm
 204mm

Andere Längen zirka 3 Wochen
 Lieferfrist
 The delivering time of special lengths is about 3 weeks

Mahlkopf Monopol aus Keramik
 Ceramic grinding head Monopol

