

Salt grinding gear Monopol with plug-in part

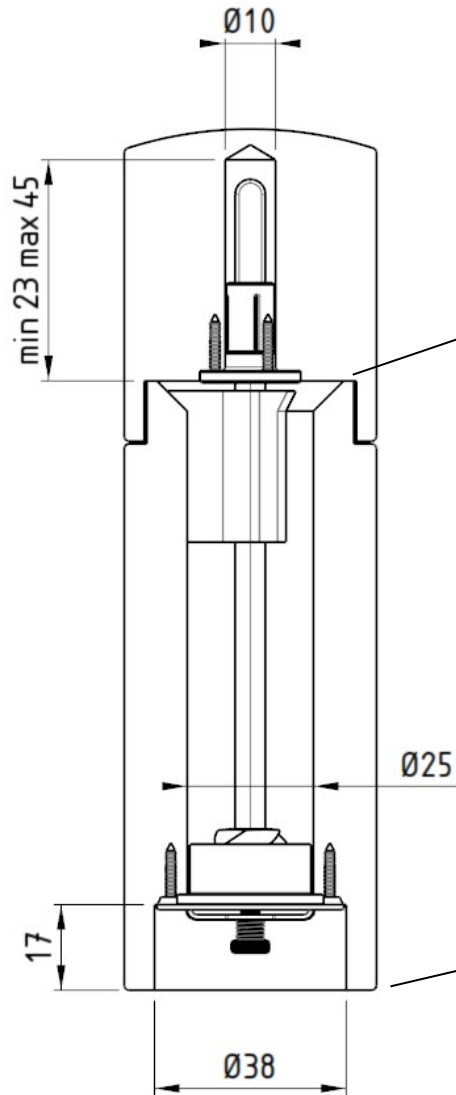

Technical instructions

To assemble the centring Y a chamfer 6x45 is needed

The M6 thread of the axle must be glued into the ceramic cone, otherwise the ceramic part can break (2K Epoxy) The end of the axle (M6) must be glued in that the axle is 1.4 - 1.5 mm inwards. This ensures optimal regulation.

The optimal diameter of the inter chamber amounts to 25mm. If it is smaller, then the peppercorns can block

Assembling dimensions of the grinding head

Attention:

The Axle of the Sonderegger pepper grinding gear and the Monopol salt grinding gear are different. Use only the salt grinding gear axle

Parts of the Monopol salt grinding gear

Plug-in part

Plastic center Y

Axle Ø6mm stainless steel

Lengths on stock

- 92mm
- 144mm
- 185mm
- 204mm

The delivery time of special lengths is about 3 weeks

Ceramic grinding head Monopol

