

Pepper grinding gear Sonderegger pluggable

Sonderegger Mechanik
 St. Antonstrasse 25
 9413 Oberegg
 Tel. 071/891 38 72 Fax 071/891 37 25
 E-Mail info@somec.ch
 www.somec.ch

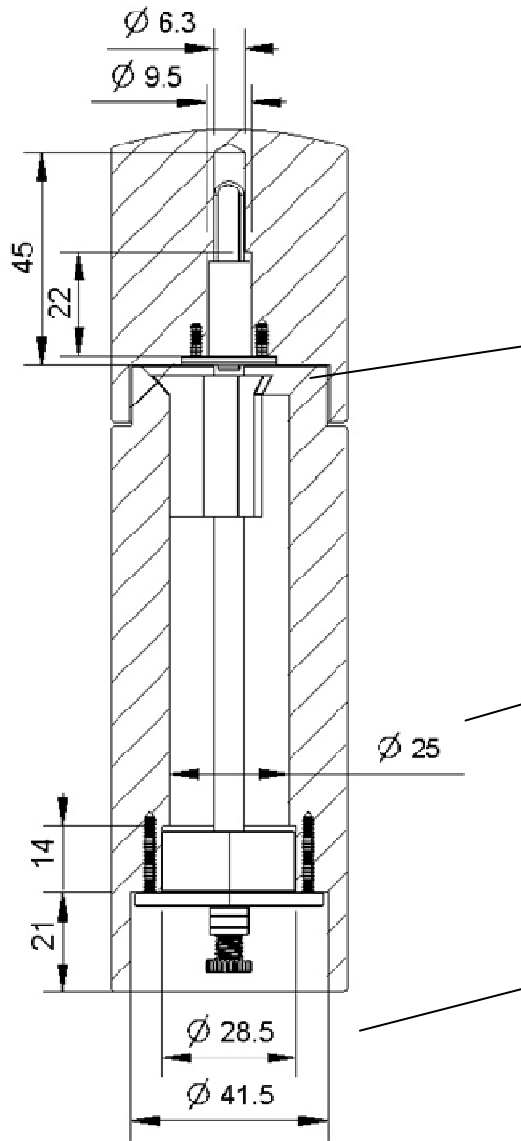

Technical instructions

To assemble the center Y a chamfer 6x45 is needed

The optimal diameter of the inter chamber amounts to 25mm. If it is smaller, then the peppercorns can block

Assembling dimensions of the grinding head

Attention:

Don't use the Sonderegger pepper grinding gear for grinding salt

Parts of the Sonderegger pepper grinding gear

Silicon tube

Driving disc Ø20, 5mm nickel plated

Plastic center Y

Axle Ø6mm stainless steel

Lengths on stock

| | |
|-------|-------|
| 92mm | 304mm |
| 144mm | 350mm |
| 204mm | 400mm |
| 250mm | 450mm |
| 278mm | 500mm |

The delivery time of special lengths is about 3 weeks

Grinding head hardened, nickel plated and pre-assembled

